

PLANTA
ESCALA 1:50

OHARRAK :
NOTAS :

LEYENDA

- VIGA HEB-200
- VIGA HEB-200
- MURO

CUADRO DE REPLANTEO		
PUNTOS	X	Y
1-A	523727.17	4807187.02
1-B	523724.37	4807188.67
1-C	523721.57	4807190.32
2-A	523725.64	4807184.43
2-B	523722.84	4807186.08
2-C	523720.04	4807187.73
2-D	523716.68	4807189.71
2-E	523713.32	4807191.69
2-F	523709.96	4807193.67
2-G	523706.60	4807195.65
3-A	523724.25	4807182.06
3-B	523721.45	4807183.71
3-C	523718.65	4807185.36
3-D	523715.29	4807187.34
3-E	523711.93	4807189.32
3-F	523708.57	4807191.30
3-G	523705.21	4807193.28
4-A	523722.85	4807179.69
4-B	523720.05	4807181.34
4-C	523717.25	4807182.99
4-D	523713.89	4807184.97
4-E	523710.53	4807186.95
4-F	523707.17	4807188.93
4-G	523703.81	4807190.91

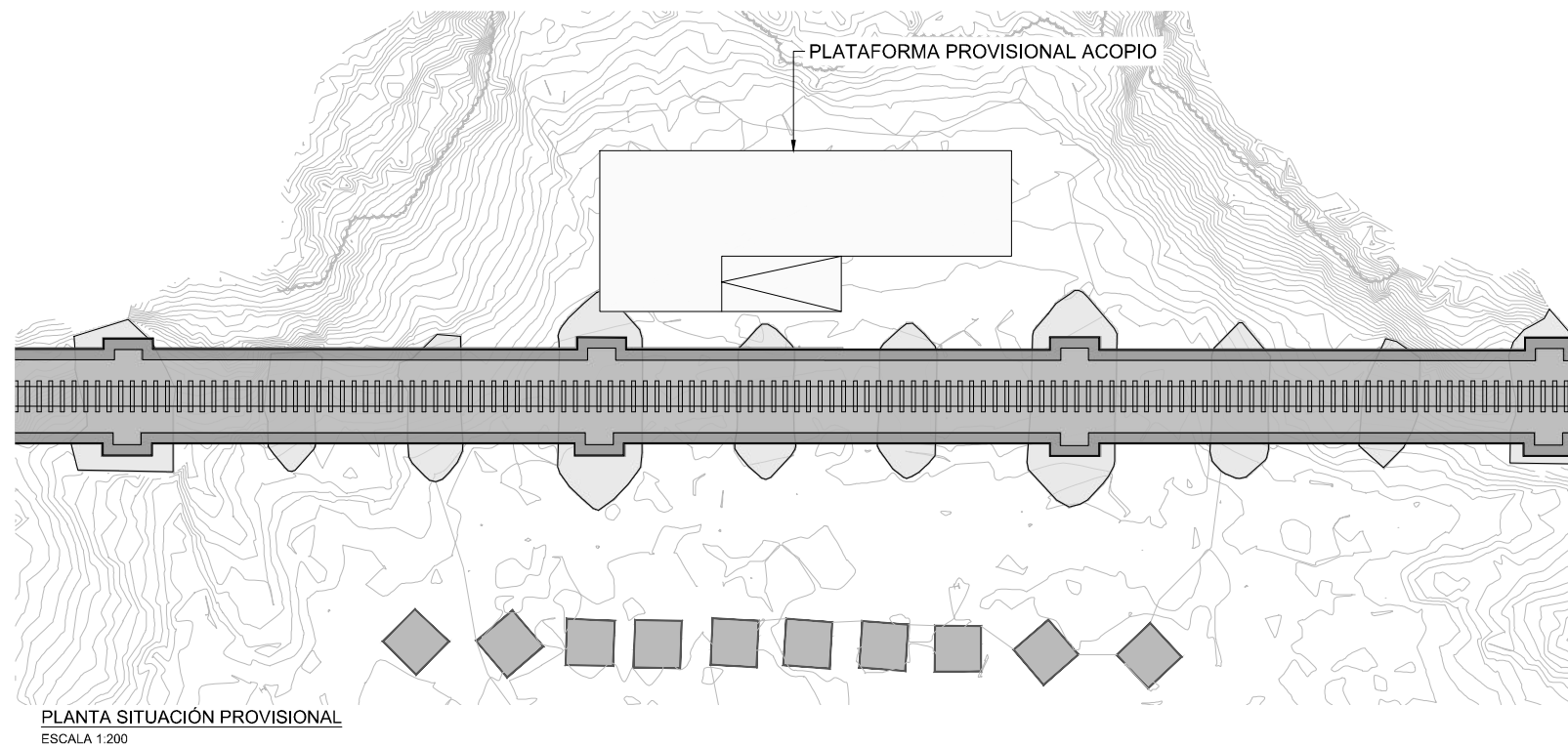
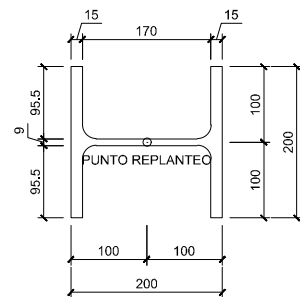

PLANTA SITUACIÓN PROVISIONAL
ESCALA 1:200

A	PRIMERA EMISION	Nov. 22			
REV.	CLASE DE MODIFICACION	FECHA	NOMBRE	COMP.	OBRA
BERRIKUSPENAK / REVISIONES					
AHOLKULARIA / CONSULTOR			INGENIARI EGILEA		
			INGENIERO AUTOR		
			JAVIER TORRONTÉGUI		
AHOLKULARIAREN ERREFERENTZIA			ERREFERENTZIA		
REFERENCIA CONSULTOR			REFERENCIA		
1-RVM-21-015-A					

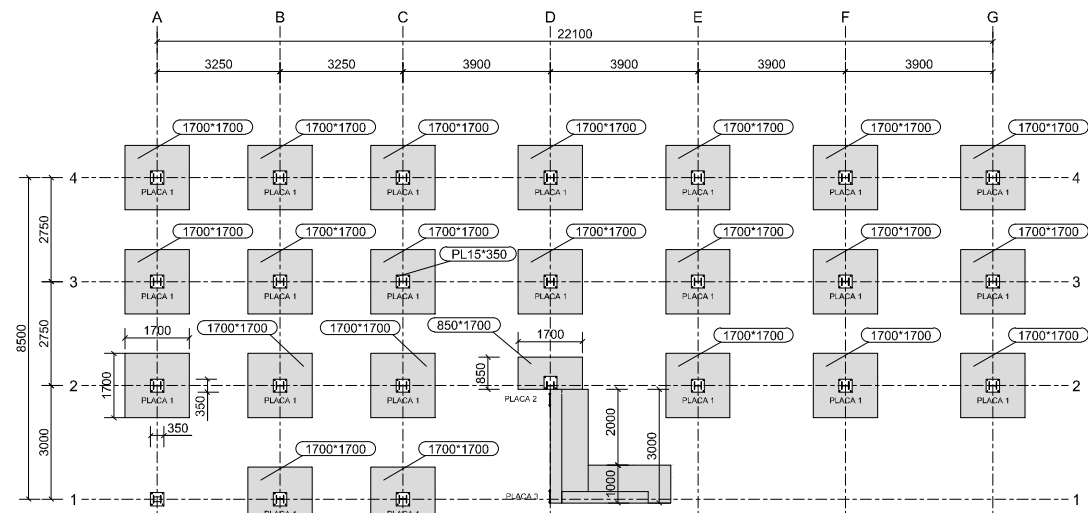

PLANTA +5394
ESCALA 1:100

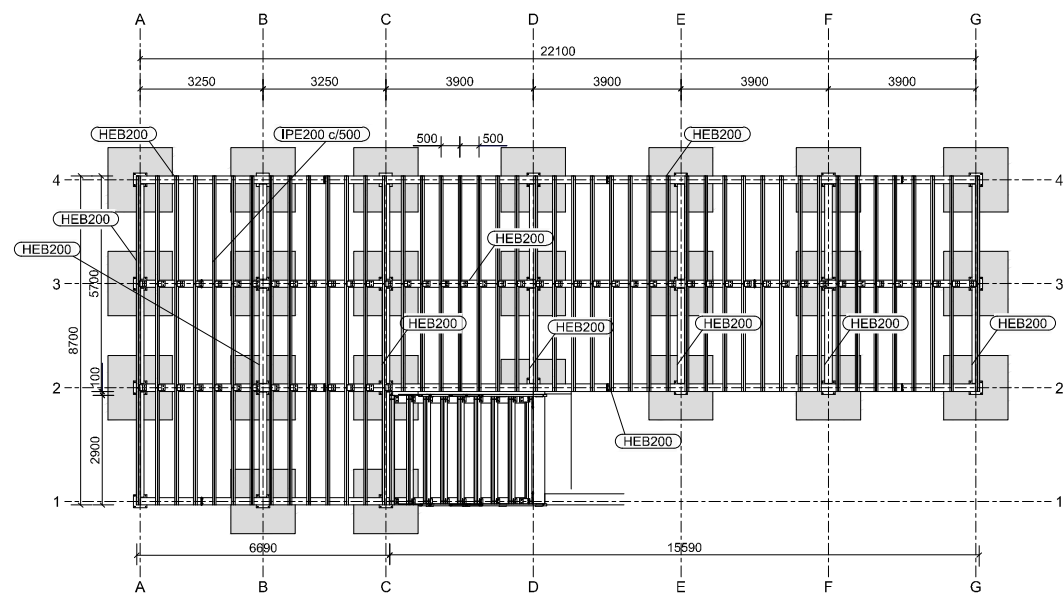

PLANTA +5694
ESCALA 1:100

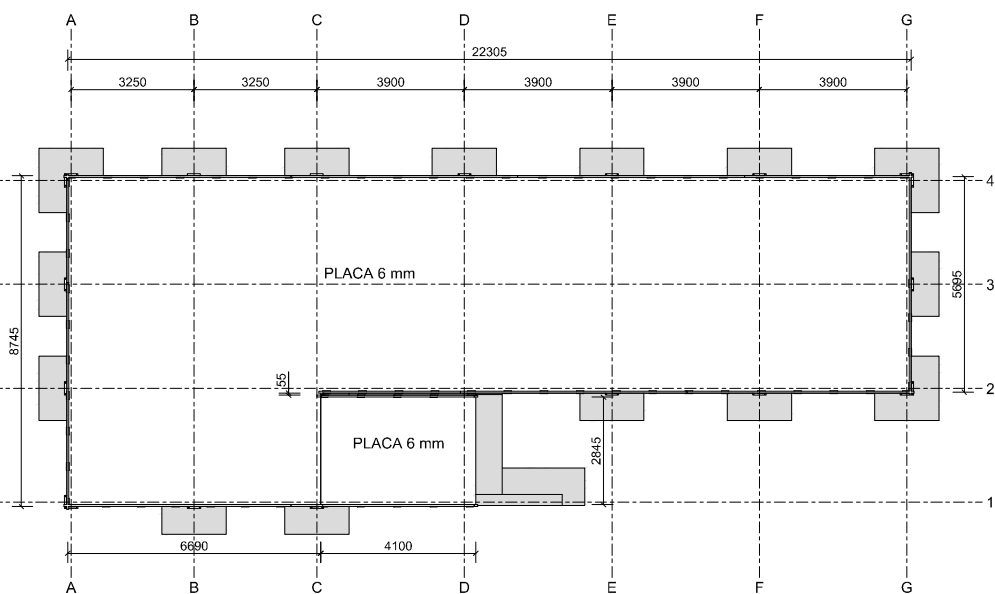

PLANTA +5800
ESCALA 1:100

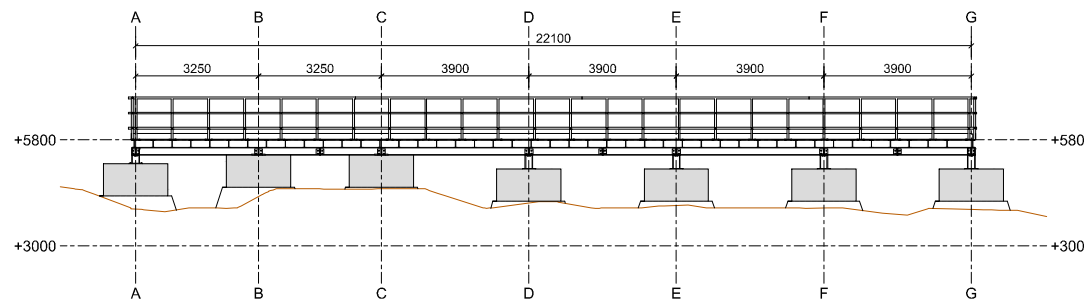

SECCIÓN EJE 4
ESCALA 1:100

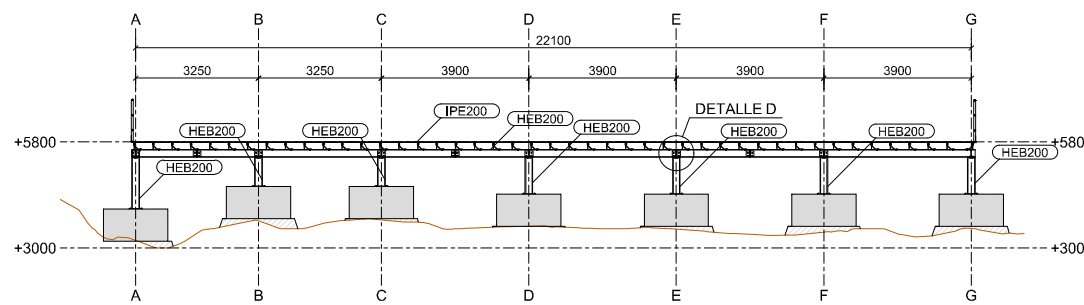

SECCIÓN EJE 3
ESCALA 1:100

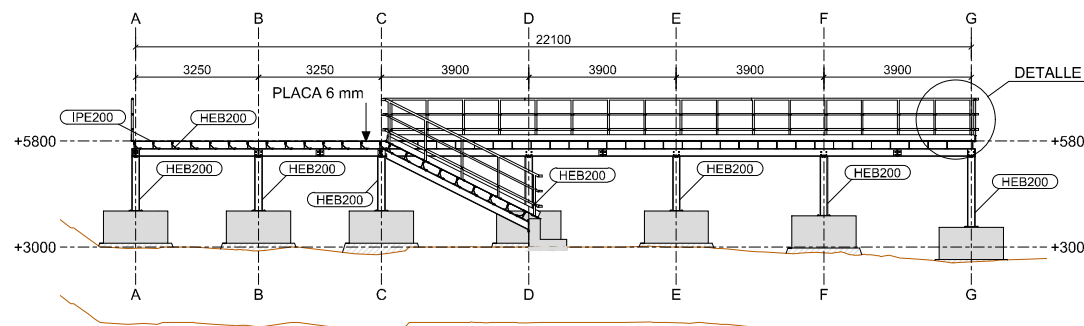

SECCIÓN EJE 2
ESCALA 1:100

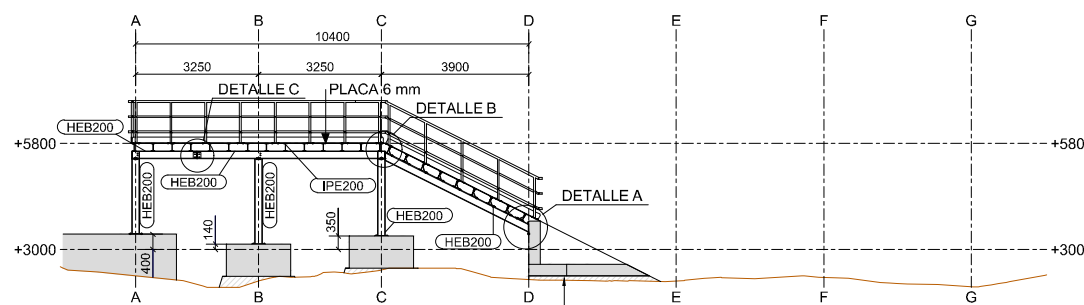

SECCIÓN EJE 1
ESCALA 1:100

OHARRAK :

NOTAS :

- EN PILA 4 SE HARÁ UNA MESETA CON MORTERO PARA GARANTIZAR LA PLANEIDAD DE LA PLACA BASE.

REV.	PRIMERA EMISION	CLASE DE MODIFICACION	FECHA	NOMBRE	COMP.	OBRA
A	PRIMERA EMISION		Nov. 22			

BERRIKUSPENAK / REVISIONES

AHOLKULARIA / CONSULTOR	INGENIARI EGILEA INGENIERO AUTOR JAVIER TORRONTÉGUI SERRANO COL. Nº 27.272

AHOLKULARIAREN ERREFERENTZIA REFERENCIA CONSULTOR	ERREFERENTZIA REFERENCIA
--	-----------------------------

1-RVM-21-016-A



OHARRAK :
NOTAS :

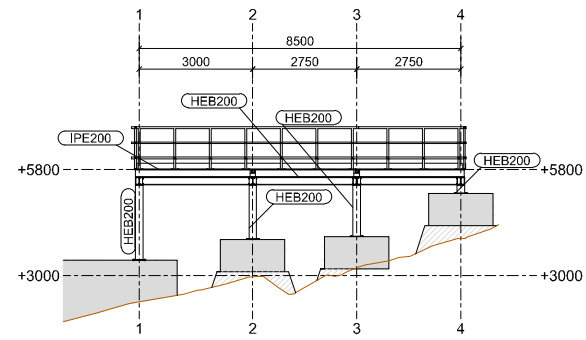

SECCIÓN EJE A
ESCALA 1:100

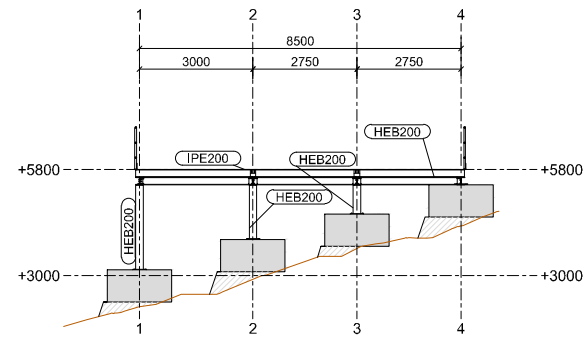

SECCIÓN EJE B
ESCALA 1:100

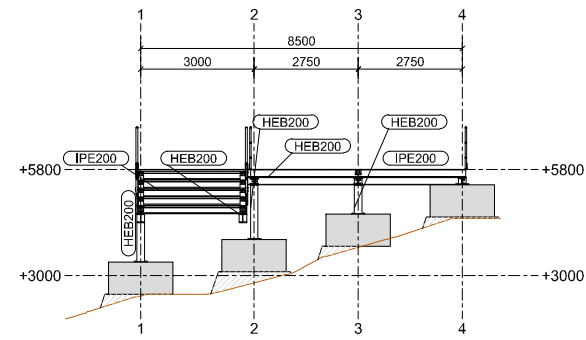

SECCIÓN EJE C
ESCALA 1:100

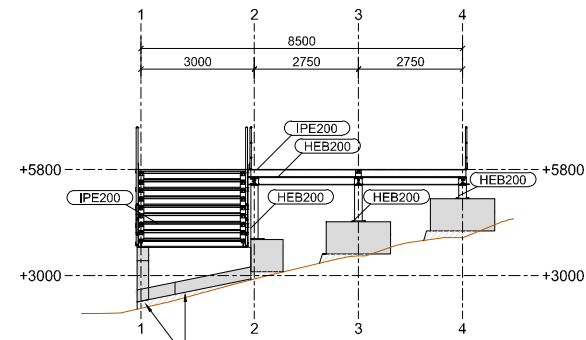

SECCIÓN EJE D
ESCALA 1:100

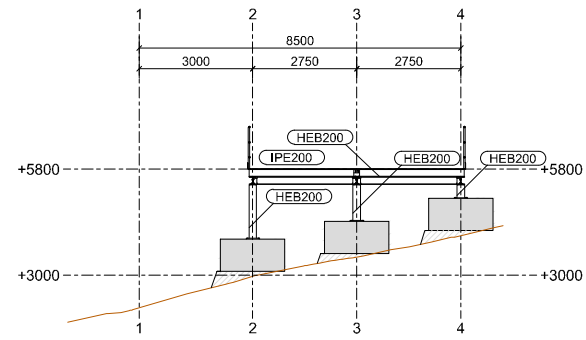

SECCIÓN EJE E
ESCALA 1:100

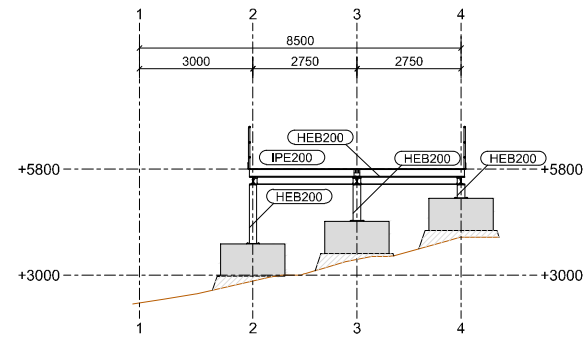

SECCIÓN EJE F
ESCALA 1:100

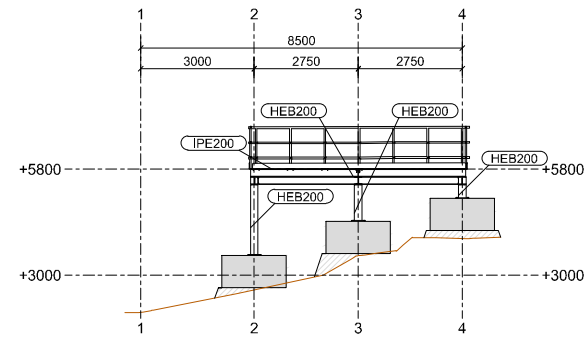

SECCIÓN EJE G
ESCALA 1:100

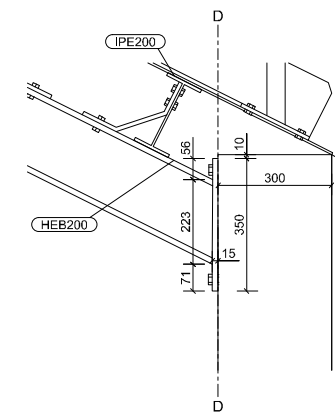
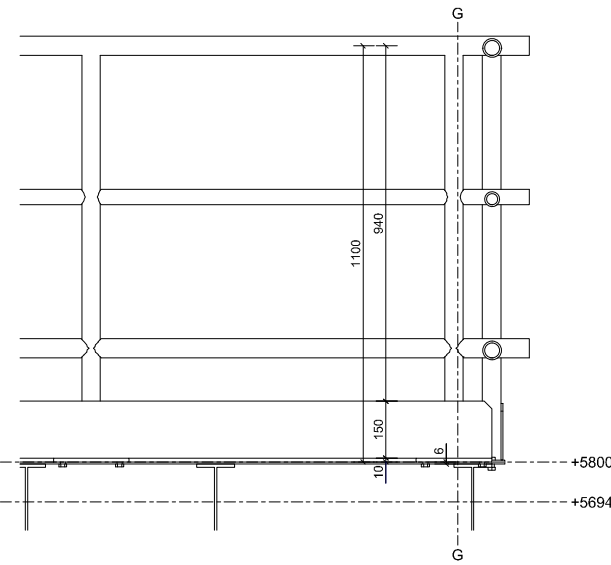

DETALLE A
ESCALA 1:10

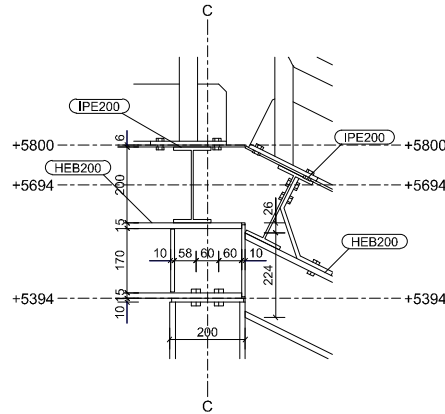

DETALLE B
ESCALA 1:10

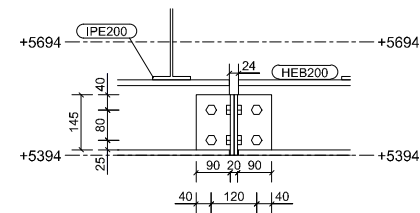

DETALLE C
ESCALA 1:10

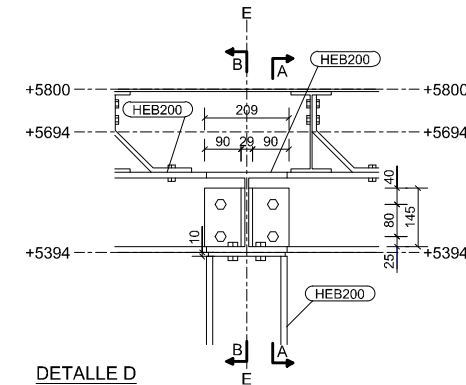

DETALLE D
ESCALA 1:10

DETALLE E
ESCALA 1:10

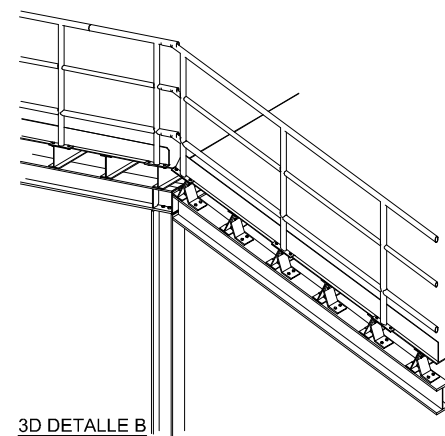

3D DETALLE B
SIN ESCALA

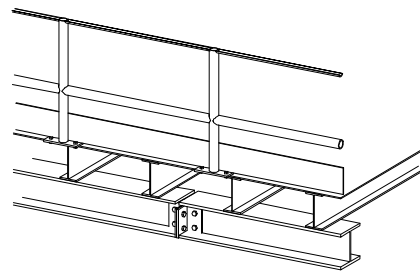

3D DETALLE C
SIN ESCALA

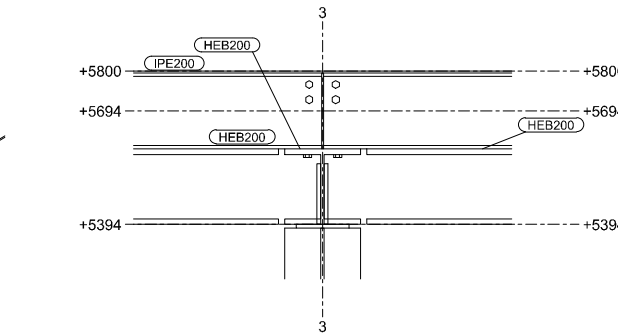

SECCIÓN A-A
ESCALA 1:10

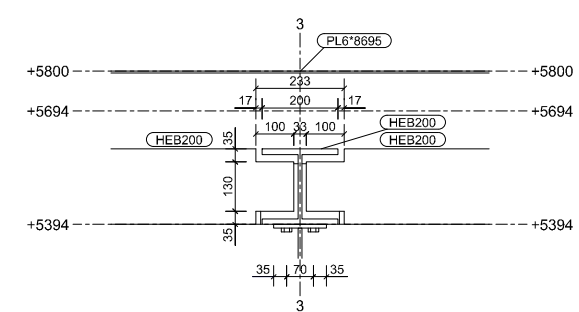

SECCIÓN B-B
ESCALA 1:10

REV.	PRIMERA EMISION	Nov. 22	CLASE DE MODIFICACION	FECHA	NOMBRE	COMP.	OBRA
BERRIKUSPENAK / REVISIONES							

AHOLKULARIA / CONSULTOR	INGENIARI EGILEA INGENIERO AUTOR JAVIER TORRONTÉGUI SERRANO COL. Nº 27.272

AHOLKULARIAREN ERREFERENTZIA REFERENCIA CONSULTOR	ERREFERENTZIA REFERENCIA
--	-----------------------------

1-RVM-21-017-A

EUSKO JAURLARITZA

GOBIERNO VASCO

LURRALDE PLANGINTZA,
ETXEBIZITZA ETA GARRAIO SAILA

DEPARTAMENTO DE PLANIFICACIÓN
TERRITORIAL, VIVIENDA Y TRANSPORTES

euskal trenbide sarea
PROIEKTUAREN IKUSKAPENA ETA ZUZENDARITZA
INSPECCIÓN Y DIRECCIÓN DEL PROYECTO

ESKALA ORIGINALA
ESCALA ORIGINAL
INDICADA
EN DIN A1

INDICADAS

ESKALA GRAFIKOA
ESCALA GRAFICA

PROIEKTUAREN IZENBURUA
TÍTULO DEL PROYECTO
MUNDAKAKO ZUBIBIAREN BABEZ ETA ERREPARAZIO ERAIKUNTZA PROIEKTUA
PROYECTO CONSTRUCTIVO DE REPARACIÓN Y PROTECCIÓN
DEL VIADUCTO DE MUNDAKA

PLANOAREN IZENBURUA
TÍTULO DEL PLANO
BILKETEN OHOLTZA.
OINPLANO, AURRETIKO BISTA ETA SEKZIOAK
PLATAFORMA DE ACOPIO.
ALZADO, PLANTA Y SECCIONES

PLANO ZK. / N. PLANO
7
ORRIA / HOJA
3 Sigue 4

OHARRAK :
NOTAS :

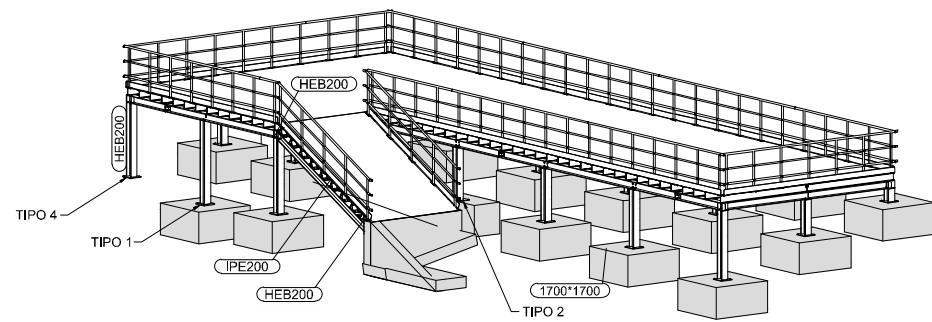

3D
ESCALA 1:100

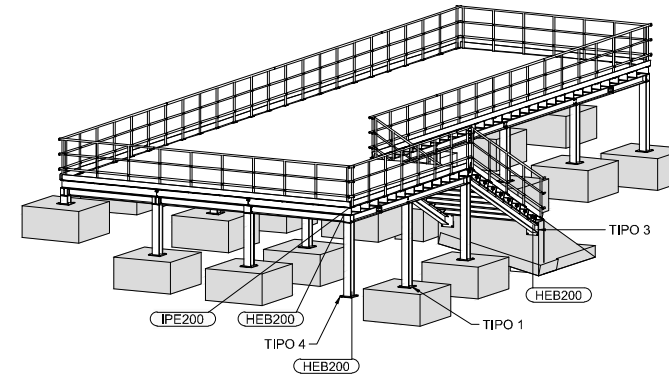

3D
ESCALA 1:100

N75, N56, N55, N58, N59, N60, N54, N53, N67, N66,
N65, N64, N63, N62, N61, N68, N69, N70, N71, N72,
N73 y N74

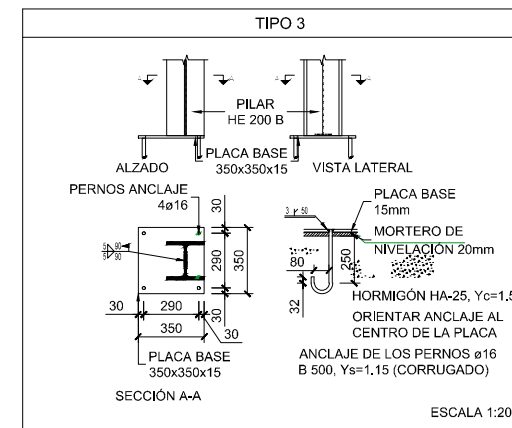
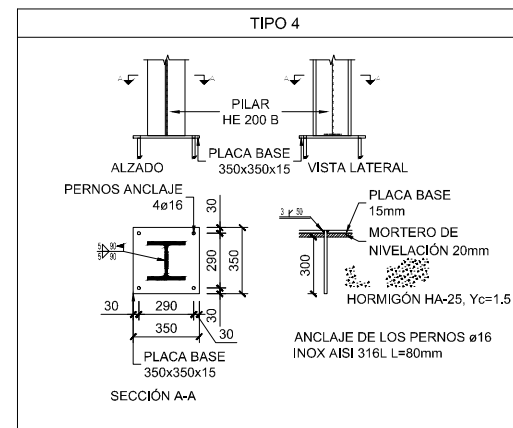
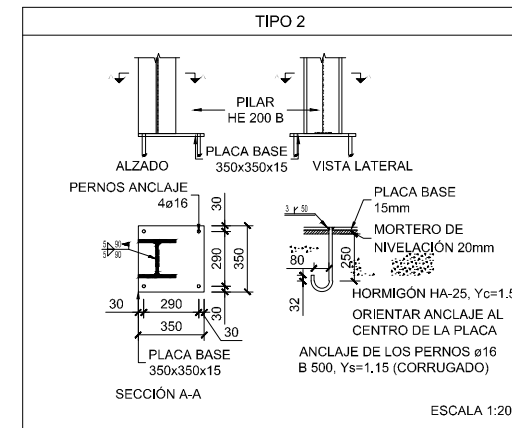
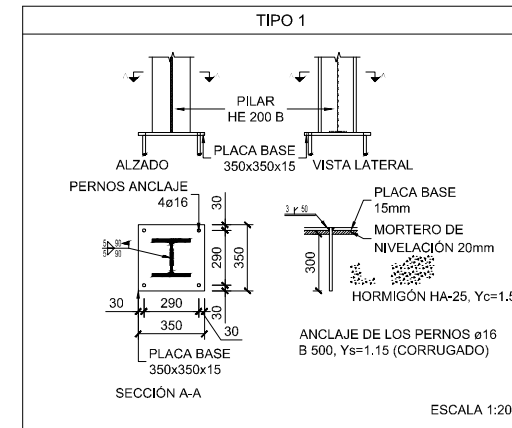
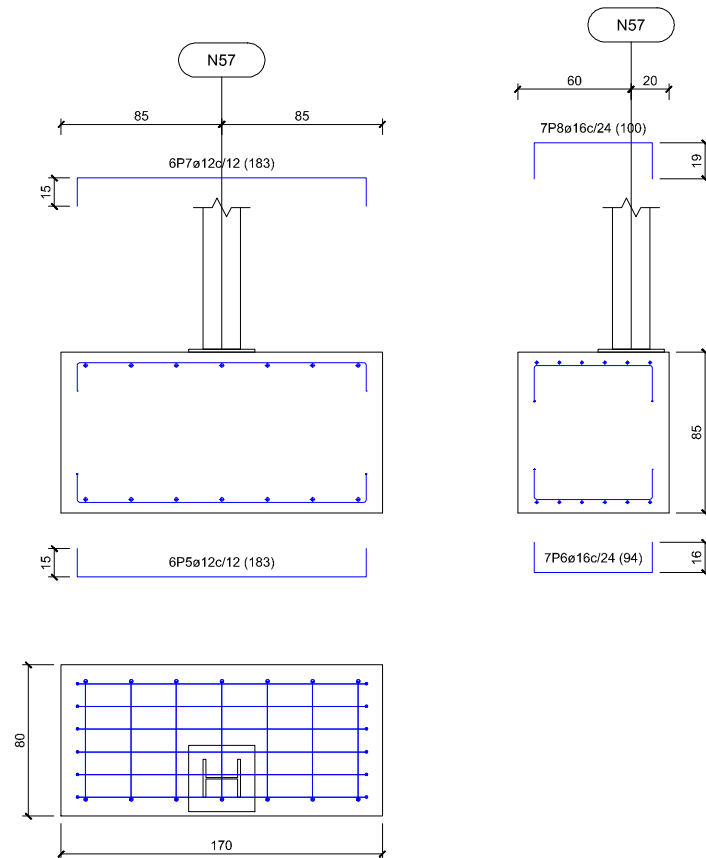
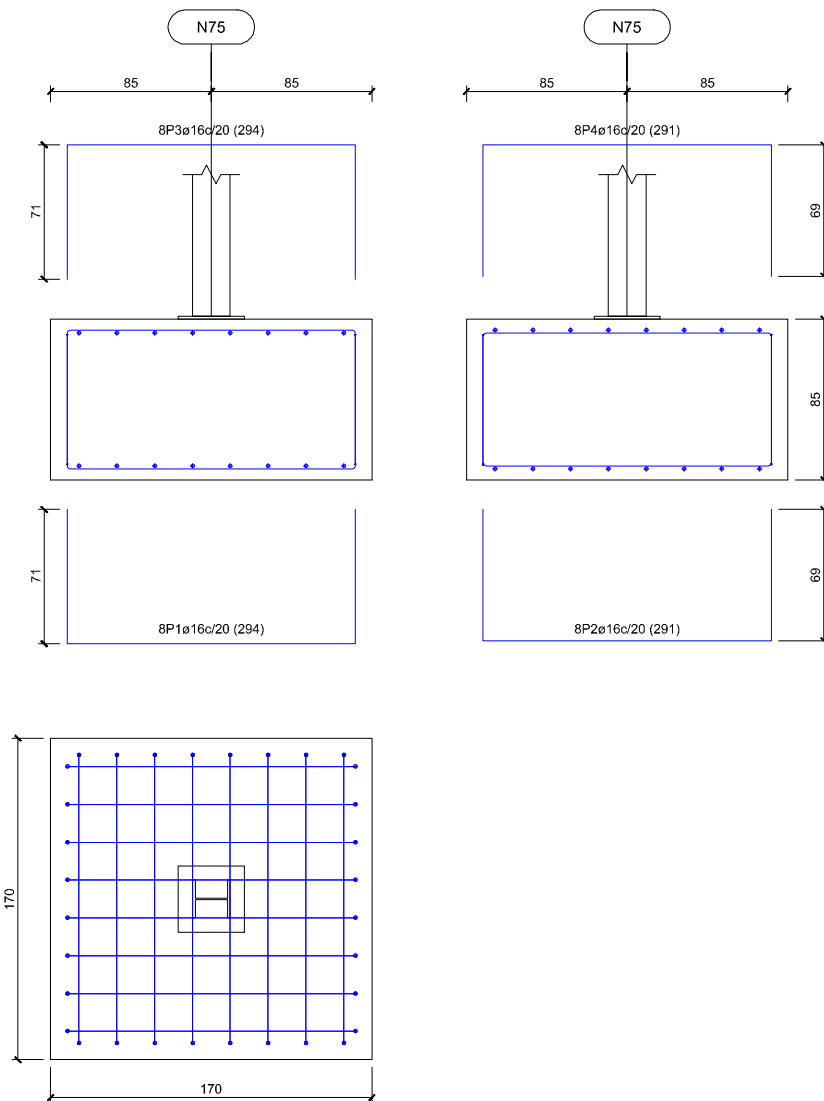

A	PRIMERA EMISION	Nov. 22			
REV.	CLASE DE MODIFICACION	FECHA	NOMBRE	COMP.	OBRA
BERRIKUSPENAK / REVISIONES					

AHOLKULARIA / CONSULTOR	INGENIARI EGLEA INGENIERO AUTOR JAVIER TORRONTÉGUI SERRANO COL. Nº 27.272
AHOLKULARIAREN ERREFERENTZIA REFERENCIA CONSULTOR	ERREFERENTZIA REFERENCIA
1-RVM-21-018-A	

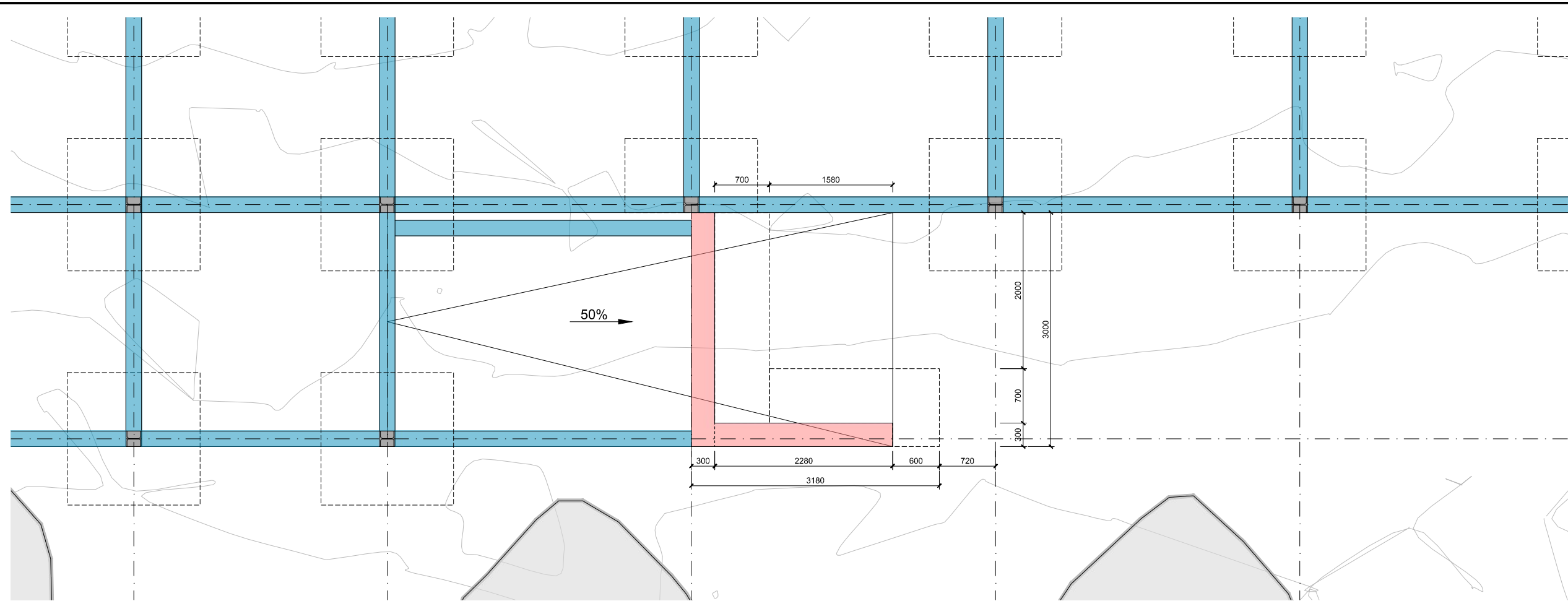

PLANTA MURO
ESCALA 1:30

OHARRAK :
NOTAS :

LEYENDA

- VIGA HEB-200
- VIGA HEB-200
- MURO

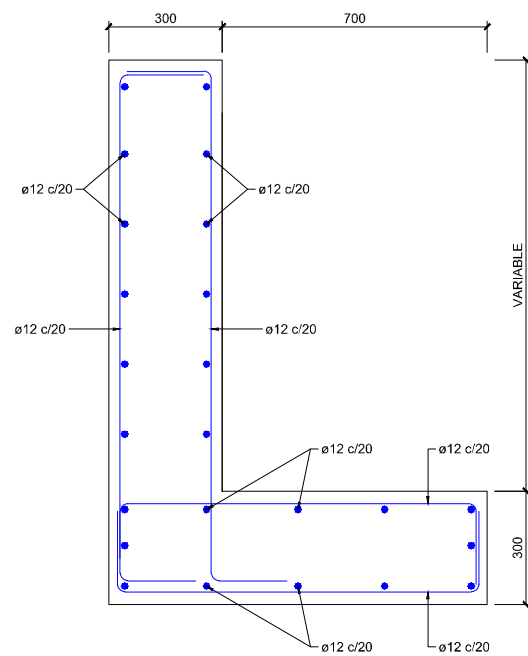

ARMADURA MURO
ESCALA 1:10

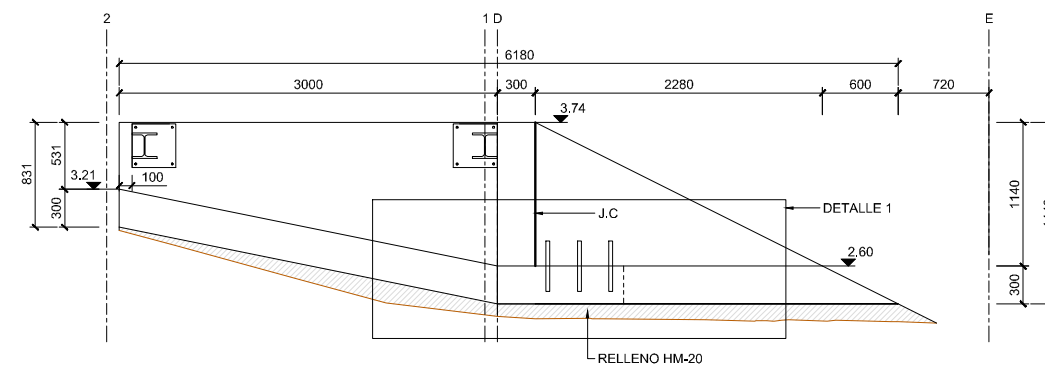

ALZADO MURO
ESCALA 1:30

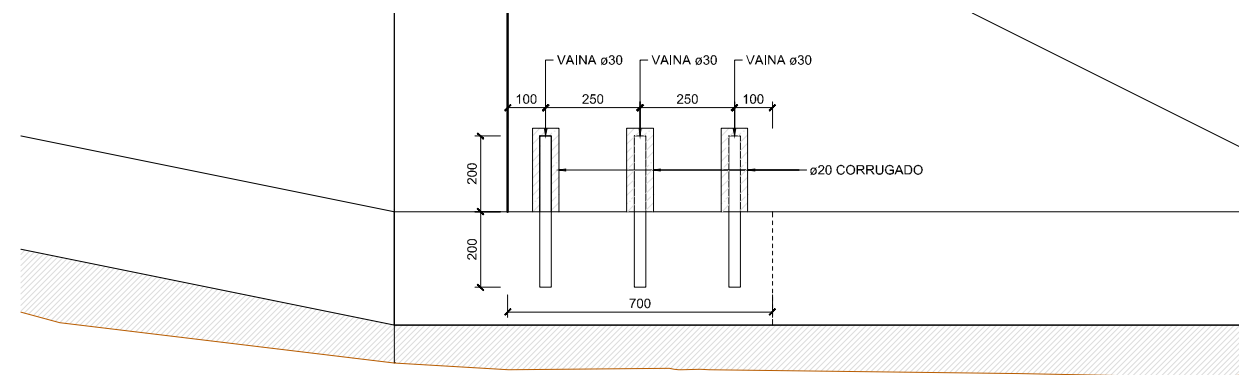

DETALLE 1
ESCALA 1:10

REV.	PRIMERA EMISION	Nov. 22			
	CLASE DE MODIFICACION	FECHA	NOMBRE	COMP.	OBRA
BERRIKUSPENAK / REVISIONES					
AHOLKULARIA / CONSULTOR			INGENIARI EGLEA		
			INGENIERO AJUTOR		
			JAVIER TORRONTÉGUI		
AHOLKULARIAREN ERREFERENTZIA			ERREFERENTZIA		
REFERENCIA CONSULTOR			REFERENCIA		
1-RVM-21-019-A					